



# Seam Types

## Contents

- Introduction •
- Seam Classification •
- Numerical Expressions of Seams •
- Seam Quality •
- Numerical Designations of Seam Types •
- Contact us about Seams •

## Introduction

In sewing, a seam is the join where two or more layers of fabric, leather, or other materials are held together with stitches. Seams in modern mass-produced apparel, footwear, house hold textiles and sporting goods are sewn by industrial sewing machines. Home shoe making, dressmaking, quilting, crafts, haute couture and tailoring may use a combination of hand and machine sewing.

In clothing construction, seams are classified by their type (plain, lapped, bound, flat) and position in the finished garment (centre back seam, inseam, side seam). Seams are finished with a variety of techniques to prevent ravelling of raw fabric edges and to neaten the inside of garments.

Seams used for assembling sewn products are load bearing and ideally should be similar in physical properties to the material being sewn. The stitch type and sewing thread used will vary with each application. Hence, it is important to be familiar with various seam types, their applications and variations available so that you can choose the right seam to suit your sewing needs.

**This technical bulletin will be your quick reference guide to seam types.**

## Seam Classification

Seams are classified according to the type / number of components used. There are eight classes of seams defined as per ISO 4916:1991.

In the past, seams were described as Flat, Superimposed, Lapped or Bound. Stitching (then differentiated from seams) were described as Edge finishing or ornamental. Varieties of seams are illustrated below together with their descriptions under the above and the new system.

### Seam Classes

- Class 1 - Superimposed seam
- Class 2 - Lapped seam
- Class 3 - Bound seams
- Class 4 - Flat seams
- Class 5 - Decorative / Ornamental stitching
- Class 6 - Edge finishing / neatening
- Class 7 - Attaching of separate items
- Class 8 - Single ply construction

#### Class 1 - Superimposed seam(s)

These generally start with two or more pieces of material superimposed over each other and joined near an edge, with one or more rows of stitches. There are various types of seams within this class.

##### Stitches Used

- A superimposed seam can be sewn with Stitch Types 301 or 401 to create a simple seam. The same seam type can also be sewn with Stitch class 500 (Over edge stitch) or Combination stitches (e.g., Stitch class 516)

##### Application

- used to create neat load bearing seams for lingerie, shirts, etc.

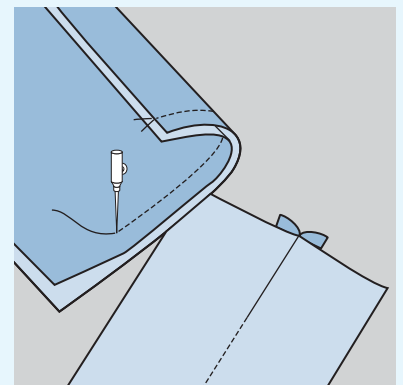

#### Class 2 - Lapped seam(s)

In this class of seam, two or more piles of material are lapped (i.e., with edges overlaid, plain or folded) and joined with one or more rows of stitches.

One of the most popular of this class is the Lap felled type, involving only one stitching operation - a strong seam with fabric edges commonly used to protect jeans or similar garments from fraying. The superficially similar French seam type involves two stitching operations with an intervening folding operation - a flat, folded seam with only one row of stitching visible on the top surface.

This seam class consists of a minimum of two components and can have different varieties consisting of a number of rows of stitching.

##### Stitches Used

- The lap felled seam is generally sewn with a 401 chainstitch

##### Application

- The looped seam is the most commonly used seam. It is used in jeans manufacture because of its strong construction. The French seam is commonly used for rain wear, and edge stitching front facings on jackets and dresses

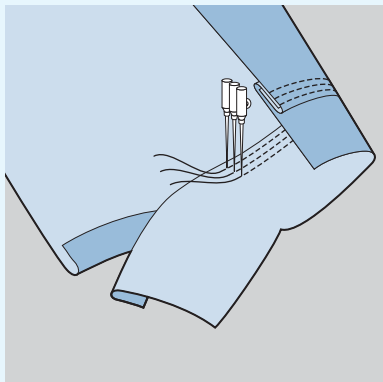

### Class 3 - Bound seam(s)

These are formed by folding a binding strip over the edge of the piles of material and joining both edges of the binding to the material with one or more rows of stitching. This produces a neat edge on a seam exposed to view or to wear. There are a variety of bound seams.

#### Stitches Used

- 401 chainstich or 301 lockstitch

#### Application

- Necklines of t-shirts

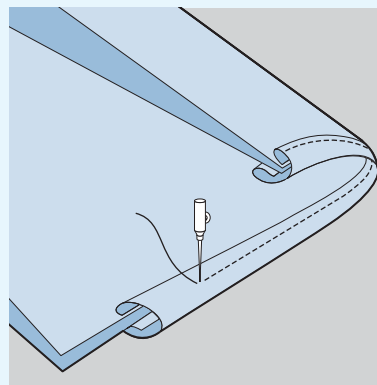

### Class 4 - Flat seam(s)

In these seams (sometimes called Butt seams), two fabric edges, flat or folded, are brought together and over sewn with stitches.

The purpose of these seams is to produce a joint where no extra thickness of fabric can be tolerated at the seam, as in underwear or foundation garments. The looper thread(s) must be soft, yet strong and the cover thread may be decorative as well as strong. This seam is referred to as a flat seam because the edges do not overlap one another, they will be butted together.

#### Stitches Used

- Zigzag lock stitch, chain stitch or covering stitch (class 600)

#### Application

- This type of seam will consist of two components and can be seen on very fine knitted garments where seams are required to be free from bulk

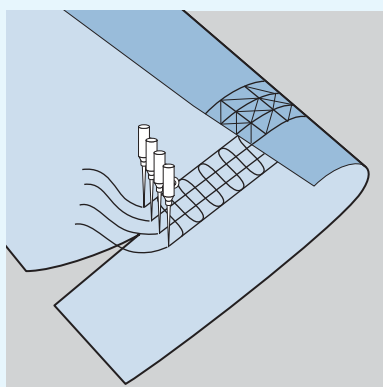

### Class 5 - Decorative / Ornamental stitching

The ornamental stitch is a series of stitches along a straight or curved line or following an ornamental design, on a single ply of material. More complex types include various forms of piping, producing a raised line along the fabric surface.

#### Application

- The stitching results in decorative surface effects on the fabric e.g., pin tucks, application of braids, etc. This seam type consists of a minimum of one component

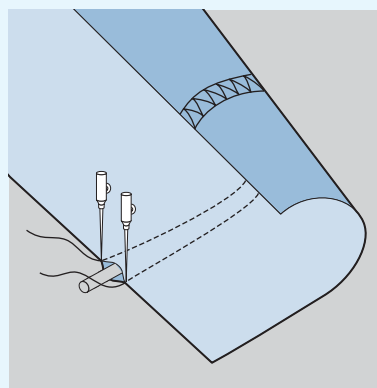

### Class 6 - Edge finishing / neatening

Edge finishing stitch is where the edge of a single ply of material is folded or covered with a stitch. The simplest of these operations is Serging, Type 6.01.01, in which a cut edge of a single ply is reinforced by over edge stitching to neaten and prevent fraying. The seam class must include seams whereby the edges are neaten by means of stitches and can be used in cases where the raw edge requires finishing. There is only ever one component to this type of seam. This includes other popular methods of producing a neat edge like hemming and blind stitch hemming.

#### Application

- Serging trouser panels, flys, facings, etc.

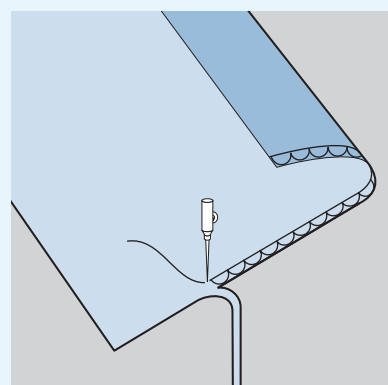
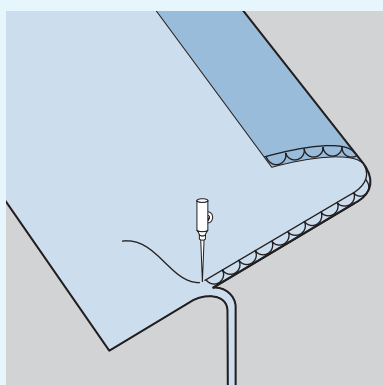



## Class 7 - Attaching of Separate Items

This seam class involves seams that require the addition of another component onto the edge of a piece of fabric e.g., elastic braid onto the edge of ladies briefs. This type of seam requires two components.

## Class 8 - Single Ply Construction

This seam class consists of one piece of fabric that is turned in on both edges. It is most commonly seen in belt loops or berts for which a folder can be attached to the machine. This type of seam requires only one component.

## Numerical Expressions of Seams

Each stitched seam is identified by a numerical designation composed of five digits.

The first digit reflects the seam class (1-8).

The second and third are counting numbers (0-99) to indicate the differences in the location of the needle penetrations.

For the seam specification to be meaningful, the designation of the stitch type has to be added after the designation of the stitched seam. If two or more stitch types are used, they should be stated from left to right.



## Seam Quality

Though the stitch types chosen for a seam depend on the functional or aesthetic requirements of the seam, seam quality can be measured based on the following parameters:

- **Seam size**  
It is measured with seam depth, seam length and seam width
- **Seam slippage strength**  
It is the amount of force required to pull out a total of  $\frac{1}{4}$ " of the opposing sets of yarns perpendicular to the seam line
- **Seam strength**  
It is the force required to break open the seam either by breaking the thread or by breaking the sewn material



Numerical Designations of Seam Types

Lapped Seams

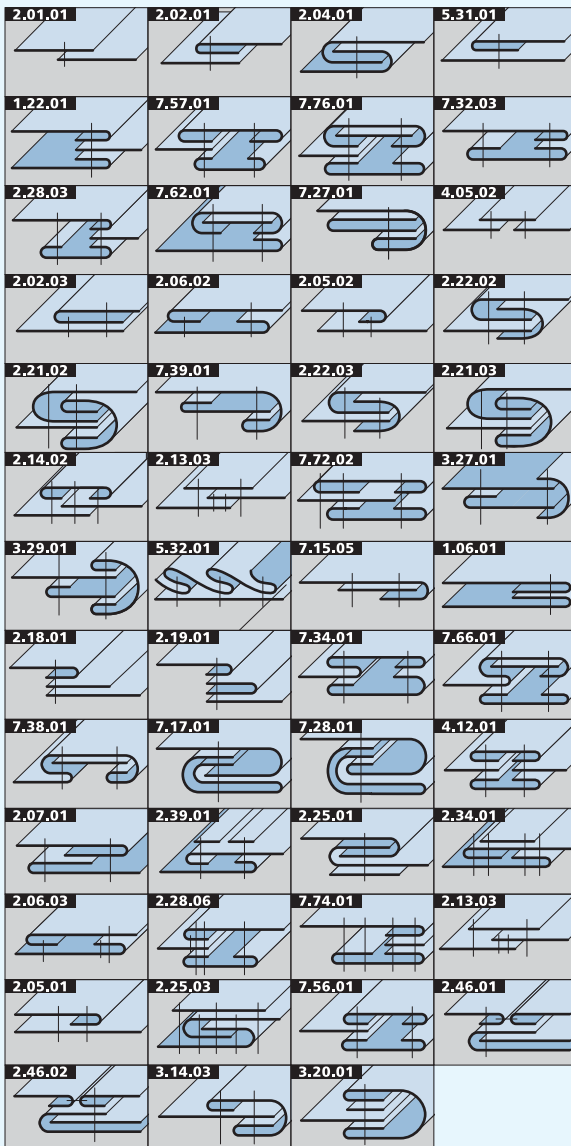

Superimposed Seams

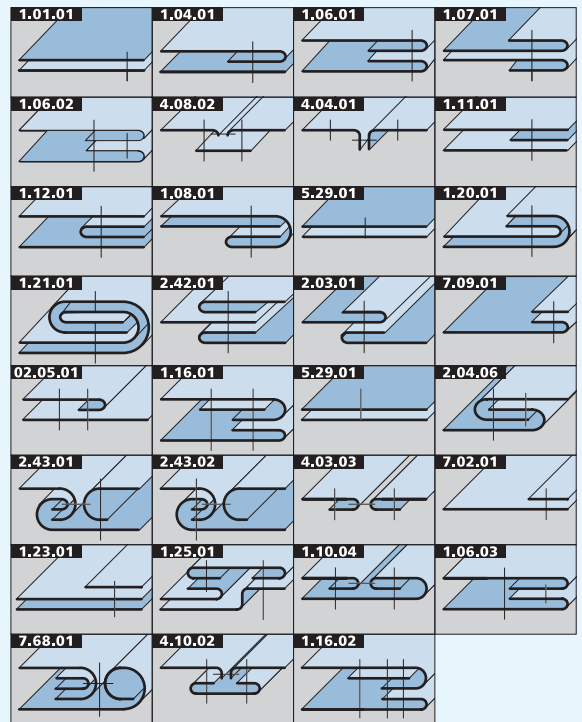

Bound Seams

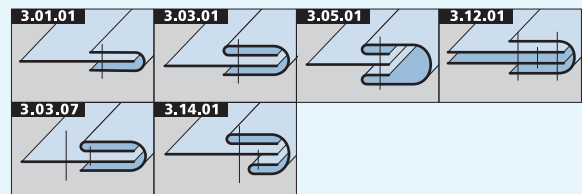

Flat Seams

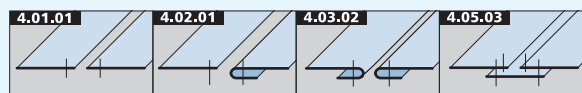

Ornamental Stitchings

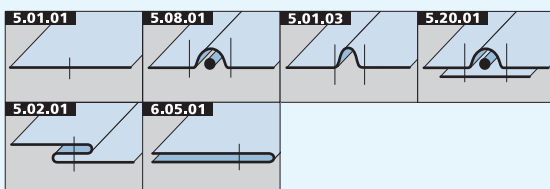

Edge Finishing Stitchings

